

Acvatix™

2- and 3- port valves with flanged connections, PN 16

VVF42..C, VVF42..KC, VXF42..C



From the large-stroke valve line. For chilled, low and high temperature water and brine.

- Performance valves for medium temperatures from -10...150°C
- Valve body of grey cast iron EN-GJL-250 or higher
- DN 25...150
- k_{vs} 6.3...400 m³/h
- Flange type 21, flange design B
- VVF42..KC with pressure compensation to handle high differential pressure
- Equipable with electro-motoric actuators SAX..., SAV... or electro-hydraulic actuators SKD..., SKB..., SKC..

In boiler, district heating and refrigeration plants, cooling towers, heating groups, in ventilation and air-handling units as control or shutoff valves.

VVF42..C, VXF42..C: For use in closed hydraulic circuits (observe cavitation).

VVF42..KC: For use in closed or open hydraulic circuits (observe cavitation).

Fields of use		Valves		
		VVF42..C	VVF42..KC	VXF42..C
Generation	Boiler plants	■	■	■
	District heating plants	■	■	-
	Refrigeration plants	■	■	■
Distribution	Heating groups	■	■	■
	Ventilation and air-handling units	■	■	■

Technical design

Mechanical design

The illustrations below show the basic design of the valves. Constructional features may differ, such as the shape of plugs.

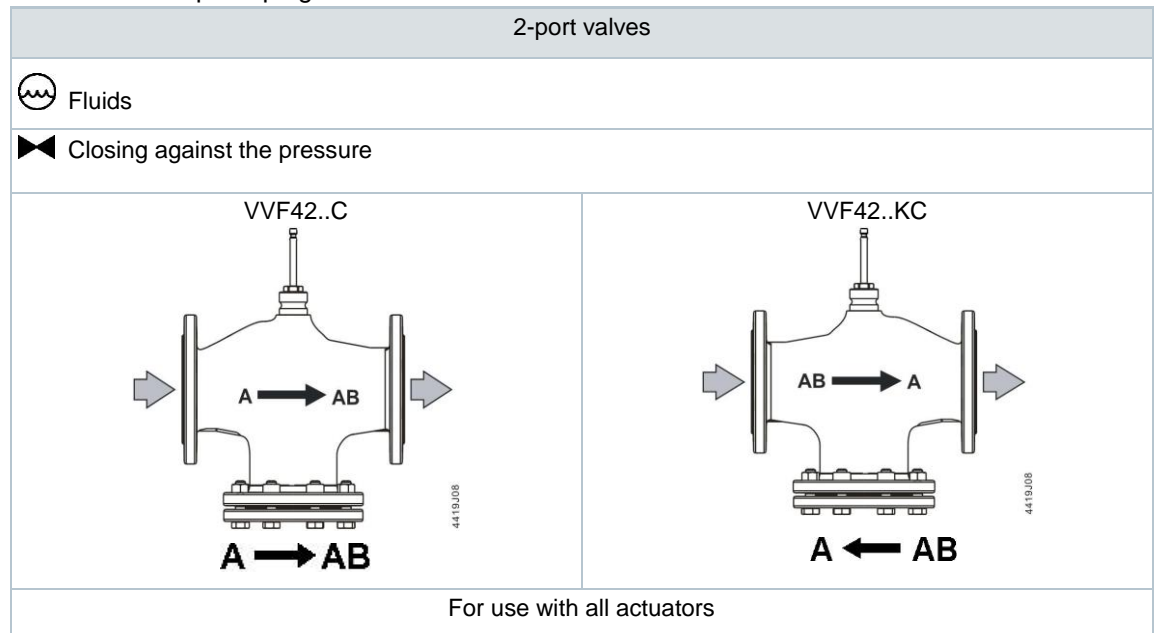

The VVF42..KC valves use a pressure-compensated plug. This enables the same type of actuators to be used for the control of volumetric flow at higher differential pressures.



2-port valves do not become 3-port valves by removing the blank flange!

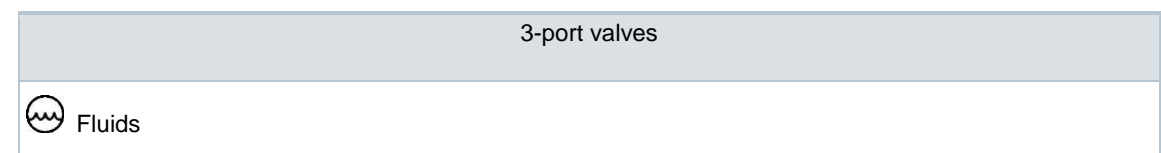



Mixing valve (preferred use)



Diverting valve

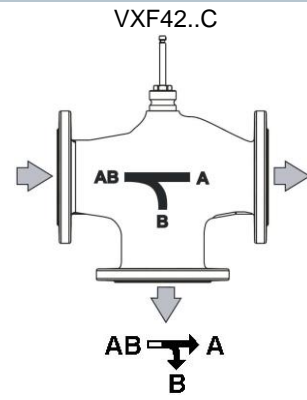
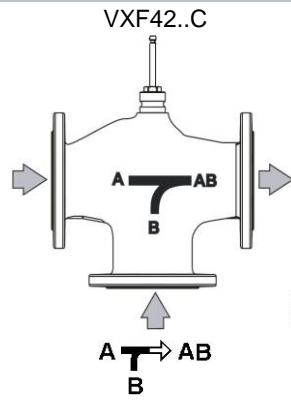

Flow chart

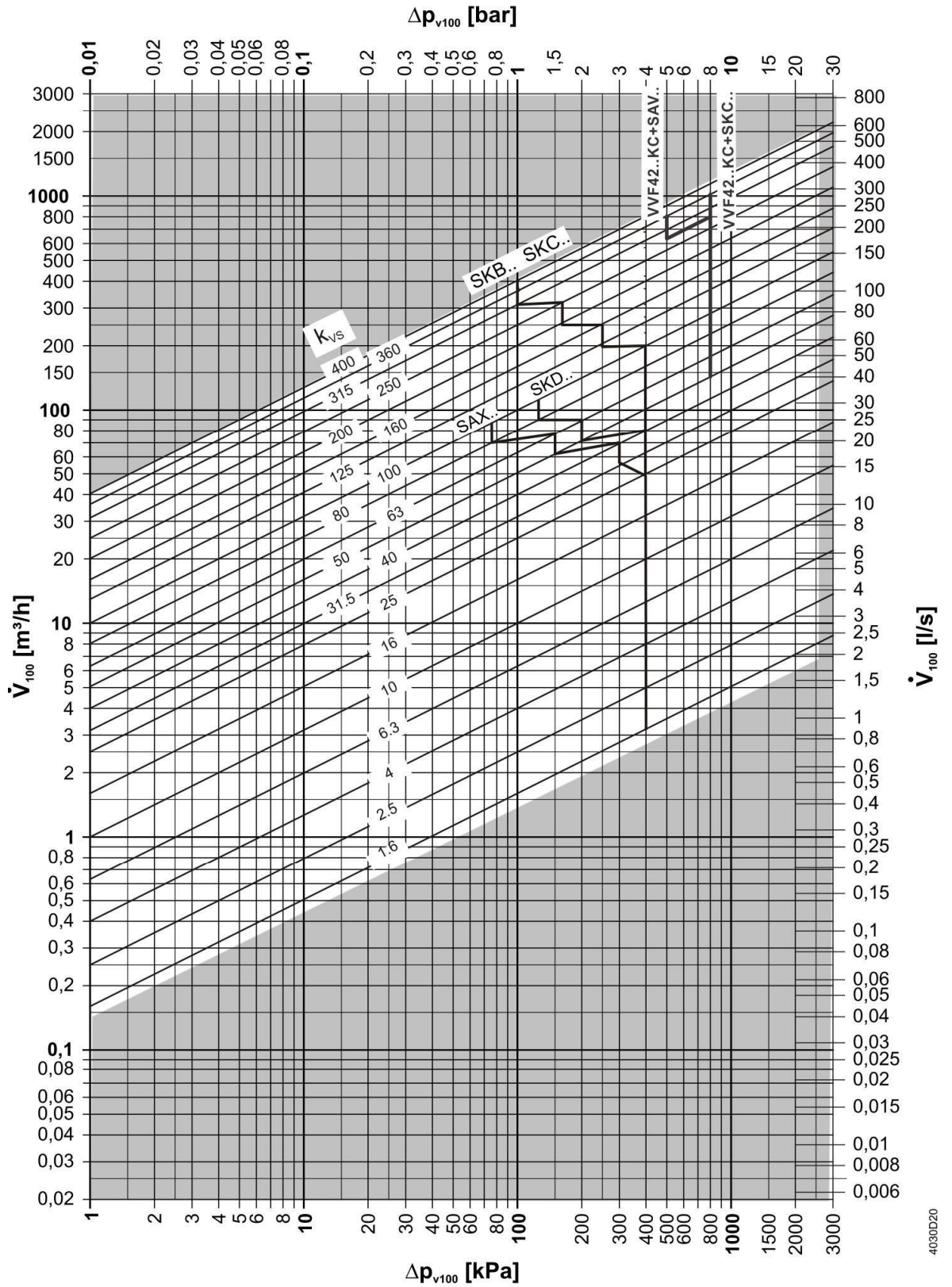

Δp_{max} values apply for the mixing function. Δp_{max} values for the diverting function, see Type summary [→7].

Valve characteristics

For figures in this section: X-axis: Stroke (H / H_{100}); Y-axis: Flow rate (k_w / k_{vs})

2-port valves		
For VVF42..C VVF42..KC other than VVF42.125-250C VVF42.150-400C		<p>0...30%: Linear 30...100%: Equal percentage ($n_{gl} = 3$ to VDI/VDE 2173)</p> <p>The design of the characteristic are according to LGBR(SBT) DN80 valve with $K_{VS}=100\text{m}^3/\text{h}$, DN100 valve with $K_{VS}=160\text{ m}^3/\text{h}$, DN150 valve with $K_{VS}=315\text{ m}^3/\text{h}$, the characteristic can be optimized for maximum volumetric flow K_{V100} at 80%... 100%</p>
For VVF42.125-250C VVF42.150-400C		<p>0... 100%: Linear</p>
3-port valves		
<p>Mixing: Flow from port A and B to AB Diverting: Flow from port AB to A and B</p>		
For VXF42..C other than VXF42.125-250C VXF42.150-400C		<p>Through port 0...30%: Linear 30...100%: $n_{gl} = 3$ as per VDI/VDE 2173</p> <p>The design of the characteristic are according to LGBR(SBT) DN80 valve with $K_{VS}=100\text{m}^3/\text{h}$, DN100 valve with $K_{VS}=160\text{ m}^3/\text{h}$, DN150 valve with $K_{VS}=315\text{ m}^3/\text{h}$, the characteristic can be optimized for maximum volumetric flow K_{V100} at 80%... 100%</p> <p>Bypass: 0... 100%: Linear</p>
For VXF42.125-250C VXF42.150-400C		<p>Through port A-AB 0... 100%: Linear Bypass B-AB 0... 100%: Linear</p>

Operating pressure and medium temperature

Operating pressure and operating temperature according to ISO 7005-2, EN 1092 and EN 12284



NOTICE

All relevant local directives must be observed.

For figures in this section: X-axis: Medium temperature (°C); Y-axis: Operating pressure (bar)

PN16 Gray Cast Iron EN-GJL-250

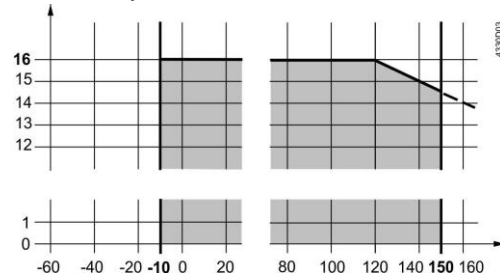

PN16 Nodular Cast Iron EN-GJS-400-18-LT

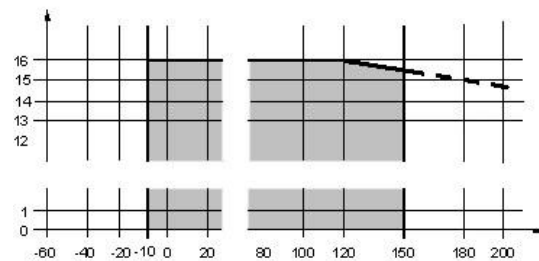

Operating pressure and medium temperature in accordance to ISO 7005, EN 1092 and EN 12284.

Medium compatibility and temperature ranges

Medium	Temperature range		Valve			Note
	T _{min} (°C)	T _{max} (°C)	VVF42..C	VVF42..KC	VXF42..C	
Cold water	1	25	■	■	■	-
Low-temperature hot water	1	130	■	■	■	-
High-temperature hot water 1)	130	150	■	■	■	-
	150	180	-	-	-	-
Water with antifreeze	-5	150	■	■	■	For medium temperature below 0°C, the stem heating ASZ6.6 has to be installed.
	-10	150	■	■	■	
	-20	150	-	-	-	
Cooling water 2)	1	25	-	■	-	-
Brines	-5	150	■	■	■	For medium temperature below 0°C, the stem heating ASZ6.6 has to be installed.
	-10	150	■	■	■	
	-20	150	-	-	-	
Super-clean water (demineralized and deionized water)	1	150	-	-	-	-
Demineralized water according to VDI 2035 / SWKI_B 102-01	1	150	■	■	■	-

1) Differentiation due to saturated steam curve
2) Open circuits

See also

Type summary [→7]

Type summary

Convention

- DN = Nominal size

- k_{vs} = Flow nominal value of cold water (5...30°C) through the fully opened valve (H_{100}) at a differential pressure of 100 kPa (1 bar)
- S_v = Rangeability
- Δp_s = Maximum permissible differential pressure at which the motorized valve still closes securely against the pressure
- Δp_{max} = Maximum permissible differential pressure across the valve through port for the entire positioning range of the motorized valve

VVF42..C	Actuators				SAX..*	SKD..	SKB..	SAV..*	SKC..					
PN16	Stroke				20 mm				40 mm					
	Positioning force				800 N	1000 N	2800 N	1600 N	2800 N					
	Data sheet				N4501	N4561	N4564	N4503	N4566					
-10...150 °C	Stock number	DN	k_{vs} m³/h	S_v	Δp_s	Δp_{max}	Δp_s	Δp_{max}	Δp_s	Δp_{max}	Δp_s	Δp_{max}	Δp_s	Δp_{max}
					[kPa]									
VVF42.25-6.3C	S55204-V148	25	6.3	> 50	1600	400	1600	400	1600	400	-	-	-	-
VVF42.25-10C	S55204-V149	25	10		900	400	1200	400	1600	400	-	-	-	-
VVF42.32-16C	S55204-V150	32	16	> 50	550	400	750	400	1600	400	1250	400	-	-
VVF42.40-16C	S55204-V151	40	16										900	400
VVF42.40-25C	S55204-V152	40	25		350	300	450	400	1200	400	750	400	-	-
VVF42.50-31.5C	S55204-V153	50	31.5	> 100	200	150	250	200	700	400	450	400	-	-
VVF42.50-40C	S55204-V154	50	40		125	75	175	125	450	400	250	225	-	-
VVF42.65-50C	S55204-V155	65	50	> 100	-	-	-	-	-	-	160	125	300	250
VVF42.65-63C	S55204-V156	65	63		-	-	-	-	-	-	125	90	190	160
VVF42.80-80C	S55204-V157	80	80	> 100	-	-	-	-	-	-	80	60	125	100
VVF42.80-100C	S55204-V158	80	100		-	-	-	-	-	-	80	60	125	100
VVF42.100-125C	S55204-V159	100	125	> 100	-	-	-	-	-	-	160	125	300	250
VVF42.100-160C	S55204-V160	100	160	> 100	-	-	-	-	-	-	125	90	190	160
VVF42.125-200C	S55204-V161	125	200	> 100	-	-	-	-	-	-	80	60	125	100
VVF42.125-250C	S55204-V162	125	250	> 100	-	-	-	-	-	-	80	60	125	100
VVF42.150-315C	S55204-V163	150	315	> 100	-	-	-	-	-	-	80	60	125	100
VVF42.150-400C	S55204-V164	150	400	> 100	-	-	-	-	-	-	80	60	125	100

* Suitable for medium temperatures up to 130°C

VVF42..KC	Actuators				SAX..*	SKD..	SKB..	SAV..*	SKC..			
PN16	Stroke				20 mm				40 mm			
	Positioning force				800 N	1000 N	2800 N	1600N	2800 N			

-10...150 °C	Data sheet				N4501		N4561		N4564		N4503		N4566	
	Stock number	DN	k _{vs} m ³ /h	S _v	Δp _s	Δp _{max}	Δp _s	Δp _{max}	Δp _s	Δp _{max}	Δp _s	Δp _{max}	Δp _s	Δp _{max}
[kPa]														
VVF42.65KC	S55204-V182	65	63	>100	1600	800	1600	800	1600	800	-	-	-	-
VVF42.80KC	S55204-V183	80	100	>100										
VVF42.100KC	S55204-V184	100	160	> 100							1600	500	1600	800
VVF42.125KC	S55204-V185	125	200	> 100	-	-	-	-	-	-				
VVF42.150KC	S55204-V186	150	315	> 100							1400			

* Suitable for medium temperatures up to 130°C

VXF42..C	Actuators				SAX..*	SKD..	SKB	SAV..*	SKC..					
PN16	Stroke				20 mm				40 mm					
	Positioning force				800 N	1000 N	2800N	1600N	2800 N					
Data sheet					N4501	N4561	N4564	N4503	N4566					
-10...150 °C	Stock number	DN	k _{vs} m ³ /h	S _v	Δp _{max} [kPa]									
VXF42.25-6.3C	S55204-V165	25	6.3	> 50										
VXF42.25-10C	S55204-V166	25	10											
VXF42.32-16C	S55204-V167	32	16		400									
VXF42.40-16C	S55204-V168	40	16			100	400	100			400	100		
VXF42.40-25C	S55204-V169	40	25											
VXF42.50-31.5C	S55204-V170	50	31.5	> 100	300			400	100					
VXF42.50-40C	S55204-V171	50	40											
VXF42.65-50C	S55204-V172	65	50	> 100	150	50	200	80						
VXF42.65-63C	S55204-V173	65	63											
VXF42.80-80C	S55204-V174	80	80	> 100	75	50	125	50			225	50		
VXF42.80-100C	S55204-V175	80	100											
VXF42.100-125C	S55204-V176	100	125	> 100	-	-	-	-	-	-	125		250	
VXF42.100-160C	S55204-V177	100	160											
VXF42.125-200C	S55204-V178	125	200	> 100	-	-	-	-	-	-	90	50	160	50
VXF42.125-250C	S55204-V179	125	250											
VXF42.150-315C	S55204-V180	150	315	> 100	-	-	-	-	-	-	60		100	
VXF42.150-400C	S55204-V181	150	400											

* Suitable for medium temperatures up to 130°C

Ordering example

Product type	Stock number	Quantity
VXF42.65-63C	S55204-V173	1
SKD32.50	BPZ:SKD32.50	1

Delivery

Valves, actuators and accessories are packed and delivered as separate items. Counter-flanges, bolts, and gaskets must be provided on site.

Spare parts

Stem sealing gland for	DN	Stock number	Example
VVF42..C VVF42..KC VXF42..C	25...80	BPZ: 428488060	
VVF42..C VVF42..KC VXF42..C	100...150	BPZ: 467956290	

Equipment combinations

SAX.. Actuators, Stroke 20 mm, Positioning force 800 N									
Product type	Stock number	Operating voltage	Positioning signal	Spring return time	Positioning time	LED	Manual adjuster	Auxiliary functions	
SAX31.000	S55150-A105	AC 230V	3-position	-	120 s	-		1)	
SAX31.03	S55150-A106								
SAX61.03	S55150-A100	AC 24V DC 24V	0..10V 4..20 mA 0...1000 Ω	-	30 s	■	Press and fix	2), 3)	
SAX61.03U	S55150-A100-A100								
SAX81.00	S55150-A102							1200 s	
SAX81.03	S55150-A103		3-position	-	30 s	-		1)	
SAX81.03U	S55150-A103-A100								
SKD.. Actuators, Stroke 20 mm, Positioning force 1000 N									
Product type	Stock number	Operating voltage	Positioning signal	Spring return time	Positioning time	LED	Manual adjuster	Auxiliary functions	
SKD32.21	BPZ:SKD32.21	AC 230V	3-position	8 s	Opening: 30 s Closing: 10 s	-		1)	
SKD32.50	BPZ:SKD32.50				-				120 s
SKD32.51	BPZ:SKD32.51				8 s				
SKD60	BPZ:SKD60	AC 24V	0..10V 4..20 mA 0...1000 Ω	-	Opening: 30 s Closing: 15 s	■	Turn, Position is maintained	2)	
SKD62	BPZ:SKD62								15 s
SKD62U	BPZ:SKD62U								
SKD62UA	BPZ:SKD62UA					4)			
SKD82.50	BPZ:SKD82.50		3-position	-	120 s	-		1)	
SKD82.50U	BPZ:SKD82.50U								
SKD82.51	BPZ:SKD82.51				8 s				
SKD82.51U	BPZ:SKD82.51U								
SKB.. Actuators, Stroke 20 mm, Positioning force 2800 N									
Product type	Stock number	Operating voltage	Positioning signal	Spring return time	Positioning time	LED	Manual adjuster	Auxiliary functions	
SKB32.50	BPZ:SKB32.50	AC 230V	3-position	-	120 s	-		1)	
SKB32.51	BPZ:SKB32.51								10 s
SKB60	BPZ:SKB60	AC 24V	0..10V 4..20 mA 0...1000 Ω	-	Opening: 120 s Closing: 10 s	■	Turn, Position is maintained	2)	
SKB62	BPZ:SKB62								10 s
SKB62U	BPZ:SKB62U								
SKB62UA	BPZ:SKB62UA					4)			
SKB82.50	BPZ:SKB82.50		3-position	-	120 s	-		1)	
SKB82.50U	BPZ:SKB82.50U								

SKB82.51 SKB82.51U	BPZ:SKB82.51 BPZ:SKB82.51U			10 s				
SKC.. Actuators, Stroke 40 mm, Positioning force 2800 N								
Product type	Stock number	Operating voltage	Positioning signal	Spring return time	Positioning time	LED	Manual adjuster	Auxiliary functions
SKC32.60	BPZ:SKC32.60	AC 230V	3-position	-	120 s	-		1)
SKC32.61	BPZ:SKC32.61			18 s				
SKC60	BPZ:SKC60	AC 24V	0..10V 4..20 mA 0...1000 Ω	-	Opening: 120 s Closing: 20 s	■	Turn, Position is maintained	2)
SKC62 SKC62U	BPZ:SKC62 BPZ:SKC62U			20 s				
SKC62UA	BPZ:SKC62UA							4)
SKC82.60 SKC82.60U	BPZ:SKC82.60 BPZ:SKC82.60U					-		120 s
SKC82.61 SKC82.61U	BPZ:SKC82.61 BPZ:SKC82.61U	3-position		18 s				

Notes

- 1) Auxiliary switch, potentiometer
- 2) Position feedback, forced control, selection of valve characteristic
- 3) Optional: sequence control, selection of acting direction
- 4) Plus sequence control, stroke limitation, and selection of acting direction

Accessories

VVF42..C, VVF42..KC, and VXF42..C

Product type	Stock number	Description	Note	Example
ASZ6.6	S55845-Z108	Stem heating element	Required for medium temperatures < 0°C	

Product documentation

Topic	Title	Document ID:
Installation	Mounting Instructions	A6V10794155, 8000081688
Background information and basic technical knowledge of valves	Basic documentation	A6V10423210

Notes

Security

 CAUTION



National safety regulations

Failure to comply with national safety regulations may result in personal injury and property damage

- Observe national provisions and comply with the appropriate safety regulations.

Engineering

Cavitation

Cavitation can be avoided by limiting the pressure differential across the valve depending on the medium temperature and prepressure.

Mounting

Mounting positions apply to both 2- and 3-port valves.

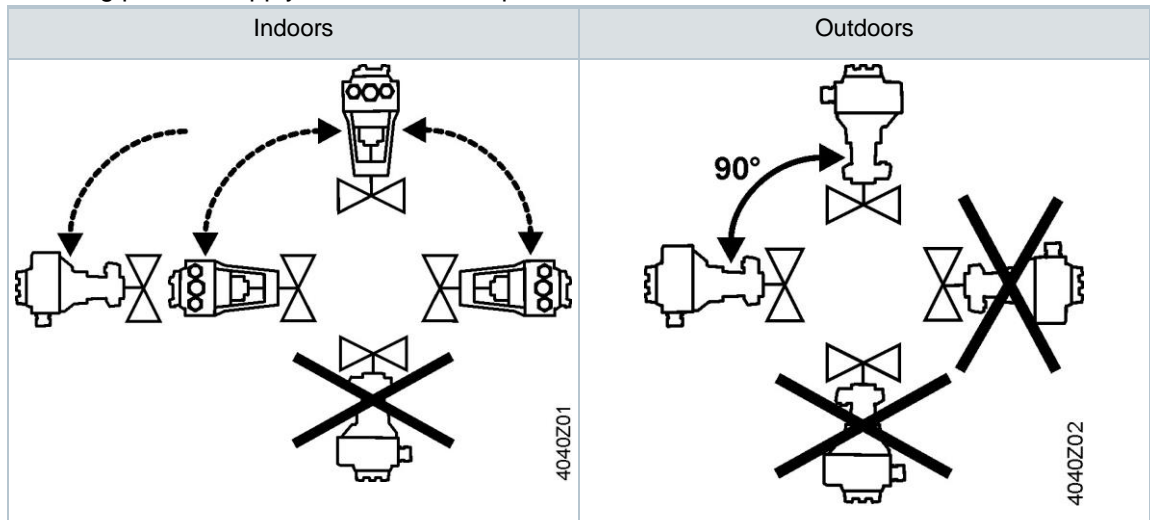

Mounting location

Preferably mount the valves at the return, as the temperature is lower there and the strain on the stem sealing gland is lower.

Dirt trap

Mount a dirt filter or dirt trap before the valve to ensure proper functioning, and a long service life of the valve. Remove dirt, welding beads, etc. from the valves and pipes.

Commissioning



⚠ WARNING

Incorrect assembly

The valve can be damaged and the leaking medium might cause human injury if the valve is put into operation without assembling the actuator or the valve correctly.

- Ensure that actuator stem and valve stem are rigidly connected in all positions.

Function check

Valve	Throughport A → B	Bypass B → AB
Valve stem extends	Closes	Opens
Valve stem retracts	Opens	Closes

Maintenance

The valves are maintenance-free.

When servicing valves or actuators:

1. Deactivate the pump and turn off the power supply.
2. Close the shutoff valves.
3. Fully reduce the pressure in the piping system and allow pipes to completely cool down. If necessary, disconnect the electrical wires.

Disposal



The valve is considered an electronics device for disposal in terms of European Directive 2012/19/EU and may not be disposed of as domestic garbage.

- Disassemble the valve into individual parts prior to disposing of it and sort the individual parts by the various types of materials.
- Comply with all local and currently applicable laws and regulations.

Warranty

Technical data on specific applications are valid only together with Siemens products listed under "Equipment combinations". Siemens rejects any and all warranties in the event that thirdparty products are used.

Technical data

The section on technical data may include the following data blocks:

Function data	
PN class	PN 16
Connection	Flange
Operating pressure	See Technical design [→6]
Valve characteristics 1)	See Technical design [→5]
Leakage rate	Through port: 0...0.02% of k_{VS} value Bypass: 0.5...2% of k_{VS} value ($k_{VS} \geq 6.3$)
Permissible media	See Technical design [→6]
Medium temperature	-10...150°C
Rangeability	To DN 40: > 50 From DN 50: >100
Nominal stroke	To DN 80: 20 mm From DN 100: 40 mm
Materials	
Valve body	DN25-DN100: HT250 which equals to EN-GJL-250 DN125-DN150: QT400-18L which equals to EN-GJS-400-18-LT
Blank flange	Same as valve body
Valve stem	Stainless steel

Seat	VVF42..C, VXF42..C: Machined VVF42..KC: Stainless steel	
Plug	DN25 Brass DN32-DN150 Stainless steel	
Stem sealing gland	Brass EPDM O-rings PTFE sleeve silicon-free	
Compensation sealing (VVF42..KC only)	Stainless steel EPDM	
Environmental conditions		
Storage IEC 60721-3-1	Class	1K3
	Temperature	-15..+55°C
	Rel. humidity	5...95% r.h.
Transport IEC 60721-3-2	Class	2K3, 2M2
	Temperature	-30...+65°C
	Rel. humidity	< 95% r.h.
Operation IEC 60721-3-3	Class	3K5, 3Z11
	Temperature	-15..+55°C
	Rel. humidity	5...95% r.h.
Standards		
Pressure Equipment Directive Pressure-carrying accessories	2014/68/EU Scope: Article 1, section 1 Definitions: Article 2, section 5	
Fluid group 2	PN 16	
	≤ DN 50	Without CE certification as per article 4, section 3 (sound engineering practice)
	DN 65...125	Category I, Module A, with CE-marking as per article 14, section 2
	DN 150	Category II, Module A2, with CE-marking as per article 14, section 2, notified body number 0035
EU conformity (CE)	DN 65...125: A5W90000768 ¹ DN150: A5W90001953 ¹	
PN class	ISO 7268	
Operating pressure	ISO 7005	
Flanges	ISO 7005	

¹ The documents can be downloaded from <http://siemens.com/bt/download>

Length of flanged valves	DIN EN 558, line 1
Valve characteristic	VDI 2173
Leakage rate	Through port, bypass according to EN 60534-4 / EN 1349
Water treatment	VDI 2035
Environmental compatibility	The product environmental declaration (A5W90000253) contains data on environmentally compatible product design and assessments (RoHS compliance, materials composition, packaging, environmental benefit, disposal).

Weight

DN		25	32	40	50	65	80	100	125	150
Weight (kg)	VVF42..C	5.0	7.4	8.9	11.9	16.7	26.6	36.5	45.7	63.6
	VVF42..KC	-	-	-	-	16.7	26.9	36.7	44.4	65.0
	VXF42..C	4.1	6.1	7.1	9.5	13.9	21.5	31.1	38.4	53.6

Dimensions

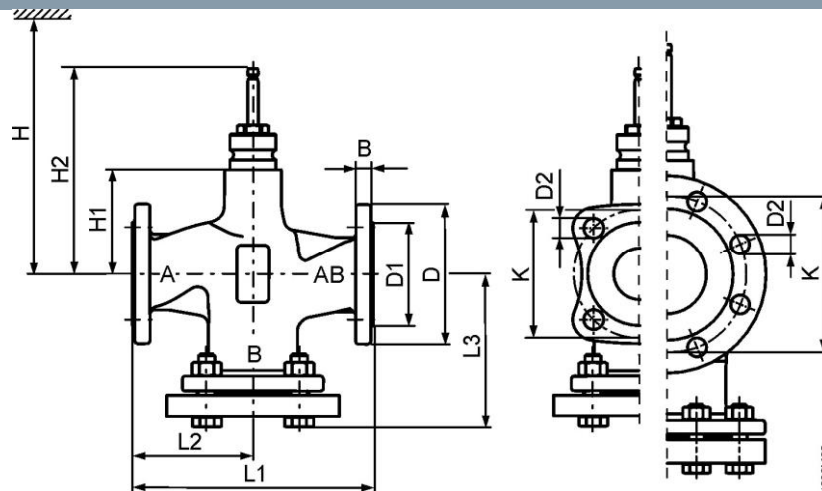

VVF42..C, VVF42..KC

Product type	DN	B	ø D	ø D1	ø D2	L1	L2	L3	ø K	H1	H2	H				
												SAX..	SKD..	SKB..	SAV..	SKC..
VVF42..C	25	13	115	65	14 (4x)	160	80	101.5	85	37	133.5	479	537	612	-	-
	32	15	140	76	19 (4x)	180	90	116	100	38	133.5	479	537	612	-	-
	40	15	150	84	19 (4x)	200	100	126	110	38	133.5	479	537	612	502	-
	50	16	165	99	19 (4x)	230	115	144	125	51.5	146.5	492	550	625	516.5	-
	65	17	185	118	19 (4x)	290	145	174	145	75	171.5	517	575	650	540	-
	80	19	200	132	19 (8x)	310	155	186	160	75	171.5	517	575	650	540	-
	100	20	220	156	19 (8x)	350	175	205	180	110	226.5	-	-	-	575	685
	125	15	250	184	19 (8x)	400	200	228	210	123	239.5	-	-	-	588	698
	150	15	284	211	23 (8x)	480	240	272.5	240	150.5	267	-	-	-	615.5	726
VVF42..KC	65	17	185	118	19 (4x)	290	145	174	145	75	171.5	517	575	650	540	-
	80	19	200	132	19 (8x)	310	155	186	160	75	171.5	517	575	650	540	-

100	20	220	156	19 (8x)	350	175	206	180	110	226.5	-	-	-	575	685
125	15	250	184	19 (8x)	400	200	228	210	123	239.5	-	-	-	588	698
150	15	284	211	23 (8x)	480	240	272.5	240	150.5	267	-	-	-	615.5	726

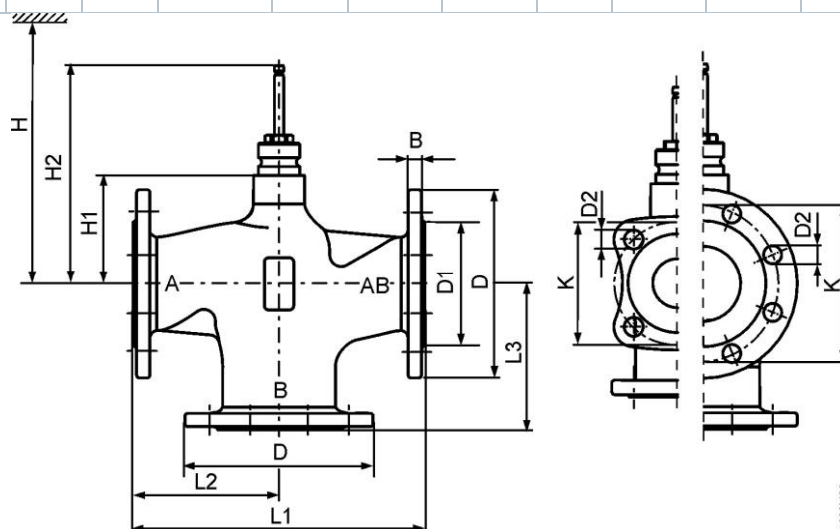

VXF42..C

DN	B	ø D	ø D1	ø D2	L1	L2	L3	ø K	H1	H2	H				
											SAX..	SKD..	SKB..	SAV..	SKC..
25 ¹⁾	13	115	65	14 (4x)	160	80	80	85	37	133.5	479	537	612	502	-
32 ¹⁾	15	140	76	19(4x)	180	90	90	100	38	133.5	479	537	612	503	-
40 ¹⁾	15	150	84	19(4x)	200	100	100	110	38	133.5	479	537	612	503	-
50 ¹⁾	16	165	99	19 (4x)	230	115	115	125	51.5	146.5	492	550	625	516.5	-
65	17	185	118	19 (4x)	290	145	145	145	75	171.5	517	575	650	540	-
80	19	200	132	19 (8x)	310	155	155	160	75	171.5	517	575	650	540	-
100	20	220	156	19 (8x)	350	175	175	180	110	226.5	-	-	-	575	685
125	15	250	184	19 (8x)	400	200	200	210	123	239.5	-	-	-	588	698
150	15	284	211	23 (8x)	480	240	240	240	150.5	267	-	-	-	615.5	726

1) Only available for VVF42..C and VXF 42..C.

Revision numbers

Type	Valid from rev. no.	Type	Valid from rev. no.
VVF42.25-6.3C	..A	VXF42.25-6.3C	..A
VVF42.25-10C	..A	VXF42.25-10C	..A
VVF42.32-16C	..A	VXF42.32-16C	..A
VVF42.40-16C	..A	VXF42.40-16C	..A
VVF42.40-25C	..A	VXF42.40-25C	..A
VVF42.50-31.5C	..A	VXF42.50-31.5C	..A
VVF42.50-40C	..A	VXF42.50-40C	..A
VVF42.65-50C	..A	VXF42.65-50C	..A

VVF42.65-63C	..A	VXF42.65-63C	..A
VVF42.80-80C	..A	VXF42.80-80C	..A
VVF42.80-100C	..A	VXF42.80-100C	..A
VVF42.100-125C	..A	VXF42.100-125C	..A
VVF42.100-160C	..A	VXF42.100-160C	..A
VVF42.125-200C	..A	VXF42.125-200C	..A
VVF42.125-250C	..A	VXF42.125-250C	..A
VVF42.150-315C	..A	VXF42.150-315C	..A
VVF42.150-400C	..A	VXF42.150-400C	..A
VVF42.65KC	..A		
VVF42.80KC	..A		
VVF42.100KC	..A		
VVF42.125KC	..A		
VVF42.150KC	..A		

Issued by
Beijing Siemens Cerberus Electronics Ltd.
Building Technologies Division
No.1, Fengzhi East Road, Xibeiwang
Haidian District, 100094 BEIJING, China
Tel. +98 21 88309733
www.sanatiyan.com

© Beijing Siemens Cerberus Electronics Ltd., 2016
Technical specifications and availability subject to change without notice.